

PIN A1 TOP VIEW OPTIONAL DUMMY DIE

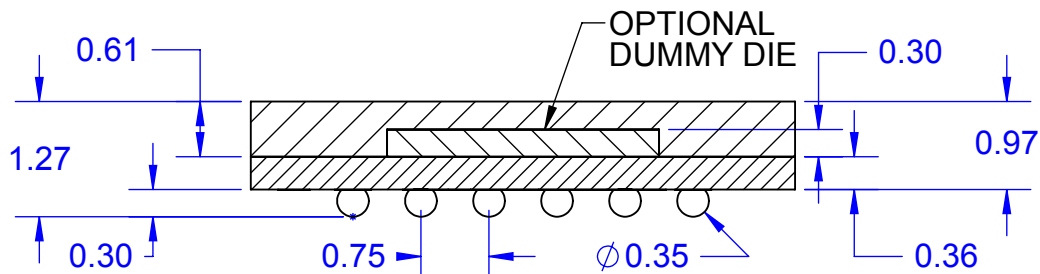

SECTION A-A

BALL VIEW PIN A1

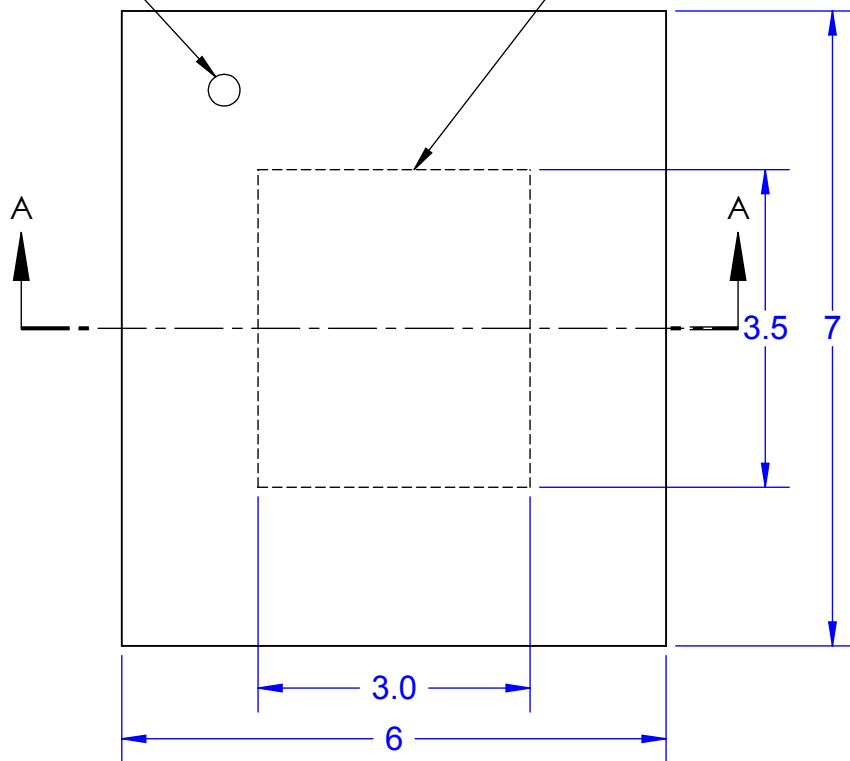
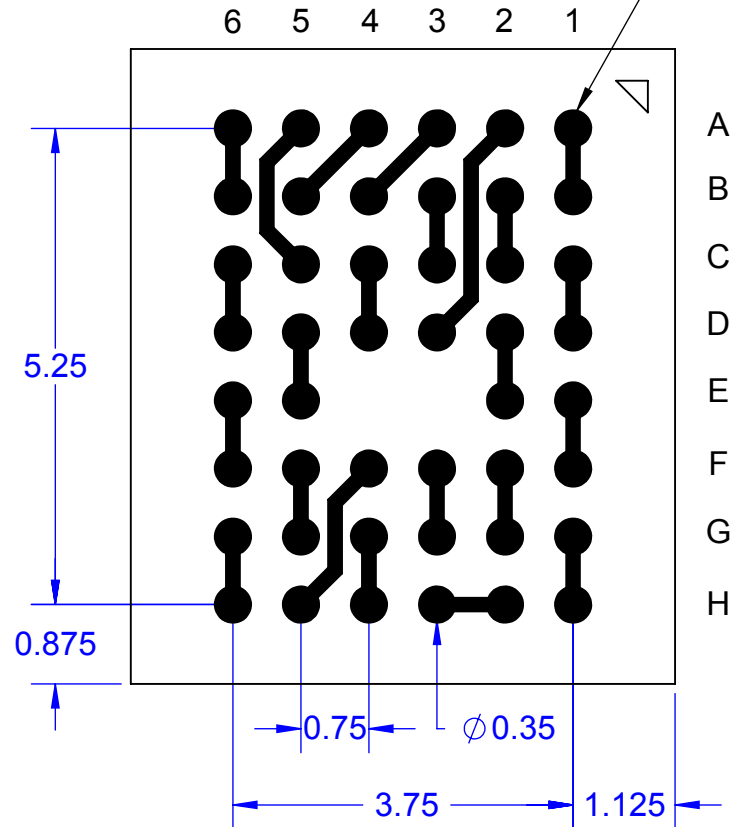

Notes: (Unless Otherwise Specified).

- 1) ALL DIMENSIONS ARE IN MM.
- 2) SOLDER BALL ALLOY: SEE PART NUMBER TABLE.
- 3) BALL DIAMETER (BEFORE REFLOW): 0.35mm.
- 4) SOLDER MASK DEFINED PAD OPENING: 0.28mm [11 MIL].
- 5) PAD Cu DIAMETER: 0.4mm [16 MIL].
- 6) SUBSTRATE MATERIAL: FR4 (ALTERNATE BT).
- 7) DUMMY DIE IS OPTIONAL.
- 8) DAISY CHAIN PATTERN (SEE PAGE 2).
- 9) MSL-3 RECOMMENDED BAKING 24 HOURS @ 125°C TO REMOVE MOISTURE PRIOR TO SOLDERING TO PC BOARD.

PART NUMBER TABLE

PART NUMBER	BALL ALLOY	BALL CODE	RoHS	Si DIE
BGA46T.75C-DC24D	Sn96.5/Ag3.0/Cu0.5	SAC305	YES	YES
BGA46T.75-DC24D	Sn63/Pb37	Sn63	NO	YES

APPROVALS		DATE				
DRAWN	T. Au	07/30/12				
ENG	M. Hart	07/30/12	TITLE		BGA46T.75-DC24 DAISY CHAIN DUMMY	
MFG			SCALE	SIZE	DRAWING NO.	REV
QA				A	570240	A
CUST			DO NOT SCALE DRAWING			SHEET 1 OF 2
REVISED						

BALL VIEW

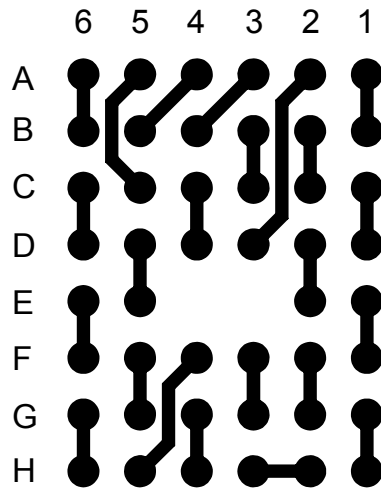

BOTTOM SIDE (TOP X-RAY VIEW)

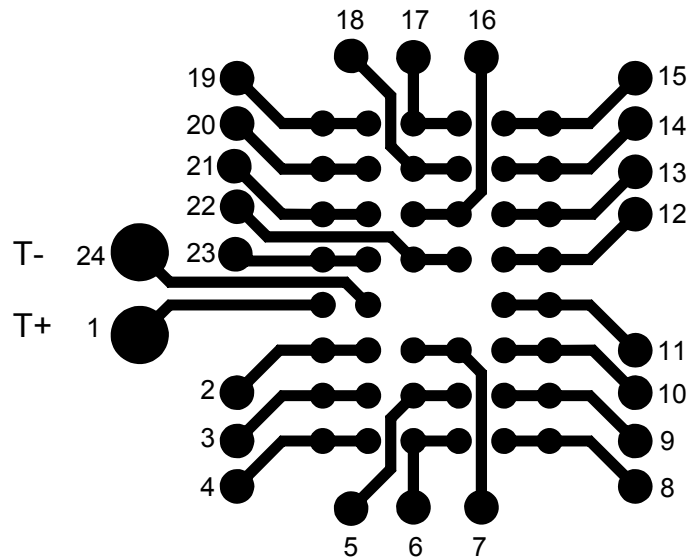
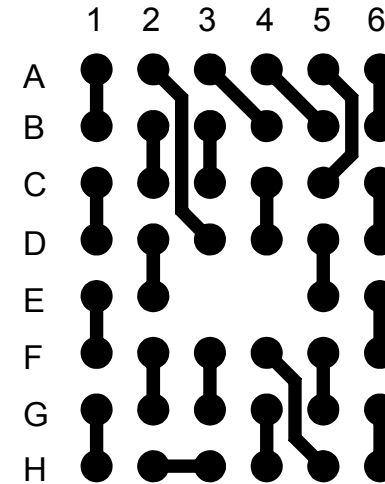

TEST VEHICLE BOARD

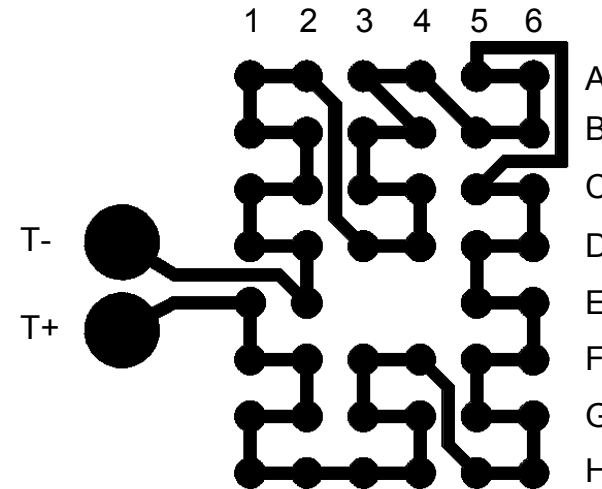

AFTER MOUNTING

Notes:

- 1) PCB BOARD DIMENSIONS ARE PRESENTED ONLY AS A GUIDELINE. DESIGNERS SHOULD USE THEIR OWN EXPERIENCE WHEN DESIGNING PCB.
- 2) PCB Cu BALL PAD DIAMETER 0.4mm [16 MIL].
- 3) PCB DAISY CHAIN TRACING LINE WIDTH 0.152mm [6 MIL].
- 4) SMD (SOLDER MASK DEFINED) PAD OPENING 0.28mm [11 MIL].

TopLine®

TITLE BGA46T.75-DC24
DAISY CHAIN DUMMY

SCALE	SIZE	DRAWING NO.	REV
	A	570240	A

DO NOT SCALE DRAWING

SHEET 2 OF 2